

# Chapter 6

## Soft-Switching dc-dc Converters Outlines

- Classification of soft-switching resonant converters
- Advantages and disadvantages of ZCS and ZVS
- Zero-current switching topologies
  - The resonant switch
  - Steady-state analyses of Quasi-resonant converters
- Zero-voltage switching topologies
  - Resonant switch arrangements
  - Steady-state analyses of Quasi-resonant converters
- Generalized analysis
  - The generalized switching cell
  - Basic Operation of the ZCS and ZVS QRC cells
- Zero-Voltage and Zero-Current transition converters
  - The Boost ZVT PWM Converter

# Types of dc-dc Converters

- **The linear power supplies**
  - *Advantages:* Simplicity in design, no electrical noise in its output, fast dynamic response time, and low cost.
  - *Disadvantages:* it can only be used as a step down regulator, Each regulator is limited to only one output, and Low efficiency when compared to other switching regulators
- **High frequency pulse width modulation (PWM) switching regulator**
  - *Advantages:* Higher efficiency, Power transistors operate at their most efficient points, Multi-output applications are possible, Size and the cost are much lower.
  - *Limitations:* Greater circuit complexity compared to the linear power supplies, High Electromagnetic Interference (EMI).

# Types of dc-dc Converters

- **Resonant converters** are used to convert dc-to-dc through a resonant network.

Advantages:

- natural commutation of power switches
- low switching power dissipation
- reduced component stresses, which in turn results in an increased power efficiency and an increased switching frequency
- higher operating frequencies result in reduced size and weight of equipment and results in faster responses; hence, a possible reduction in EMI problems

## Resonant vs. Conventional PWM

- In PWM converters, the switching of semiconductor devices normally occurs at high current levels. Therefore, when switching at high frequencies these converters are associated with high power dissipation in their switching devices.
- Furthermore, the PWM converters suffer from EMI caused by high frequency harmonic components associated with their quasi-square switching current and/or voltage waveforms.
- In the resonant techniques, the switching losses in the semiconductor devices are avoided due to the fact that current through or voltage across the switching device at the switching point is equal to or near zero.
- Compared to the PWM converters, the resonant converters show a promise of achieving the design of small size and weight converters.
- Another advantage of resonant converters over PWM converters is the decrease of the harmonic content in the converter voltage and current waveforms.

# Classification of soft-Switching Resonant Converters

- Quasi-resonant converters (single-ended)
  - Zero-current switching (ZCS)
  - Zero-voltage switching (ZVS)
- Full-resonance converters (conventional)
  - Series resonant converter (SRC)
  - Parallel resonant converter (PRC)
- Quasi-squarewave (QSW) converters
  - Zero-current switching (ZCS)
  - Zero-voltage switching (ZVS)
- Zero Transition Topologies
  - Zero-voltage transition (ZVT)
  - Zero-current transition (ZCT)

# Advantages and Disadvantages of ZCS and ZVS

- Power switch is turned *ON* and *OFF* at Zero-Voltage and Zero-Current
- In ZCS topologies, the rectifying diode has ZVS
- In ZVS topologies, the rectifying diode has ZCS
- In isolated topologies, both the ZVS and the ZCS utilize transformer leakage inductances and diode junction capacitors and the output parasitic capacitor of the power switch.
- Some ZVS and ZCS techniques requires variable-frequency control to regulate the output, which is a disadvantage.
- In ZCS, the power switch turns-*OFF* at zero current but at turn-*ON*, the converter still suffers from turn-*ON* loss caused by the output capacitor of the power switch.

# Switching Locus

- Typical switching loci for a hard-switching converter without and with a snubber circuit as shown in Fig. 6.2.

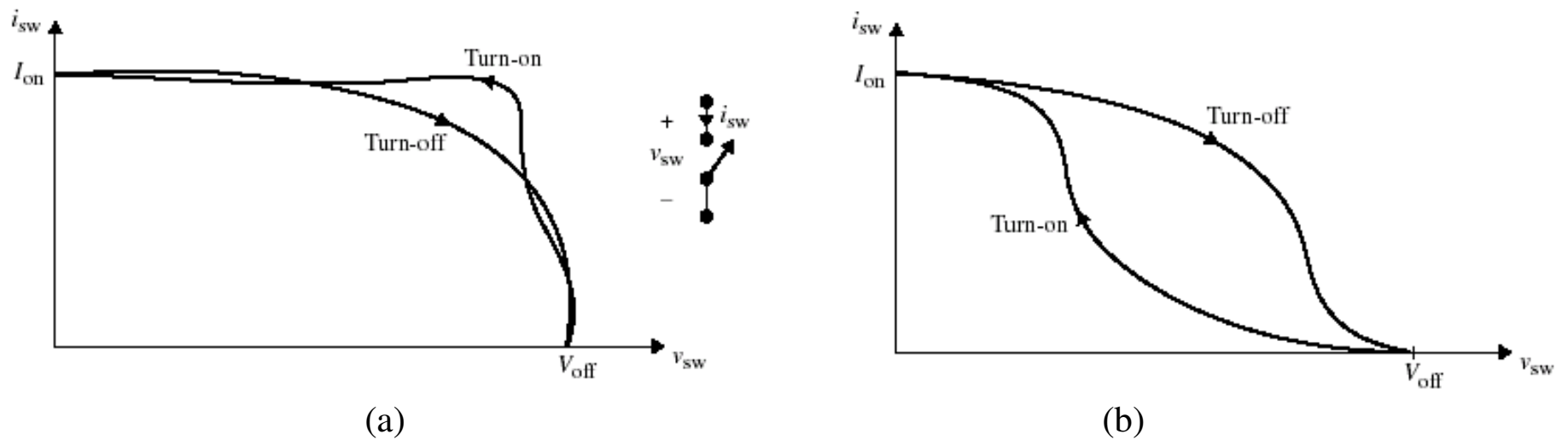

**Fig 6.2** Switching loci. (a) Without snubber circuit. (b) With snubber circuit.

*Snubber is a circuit that is used used to suppress ("snub") voltage transients and smoothes switching waveforms*

# Switching Losses

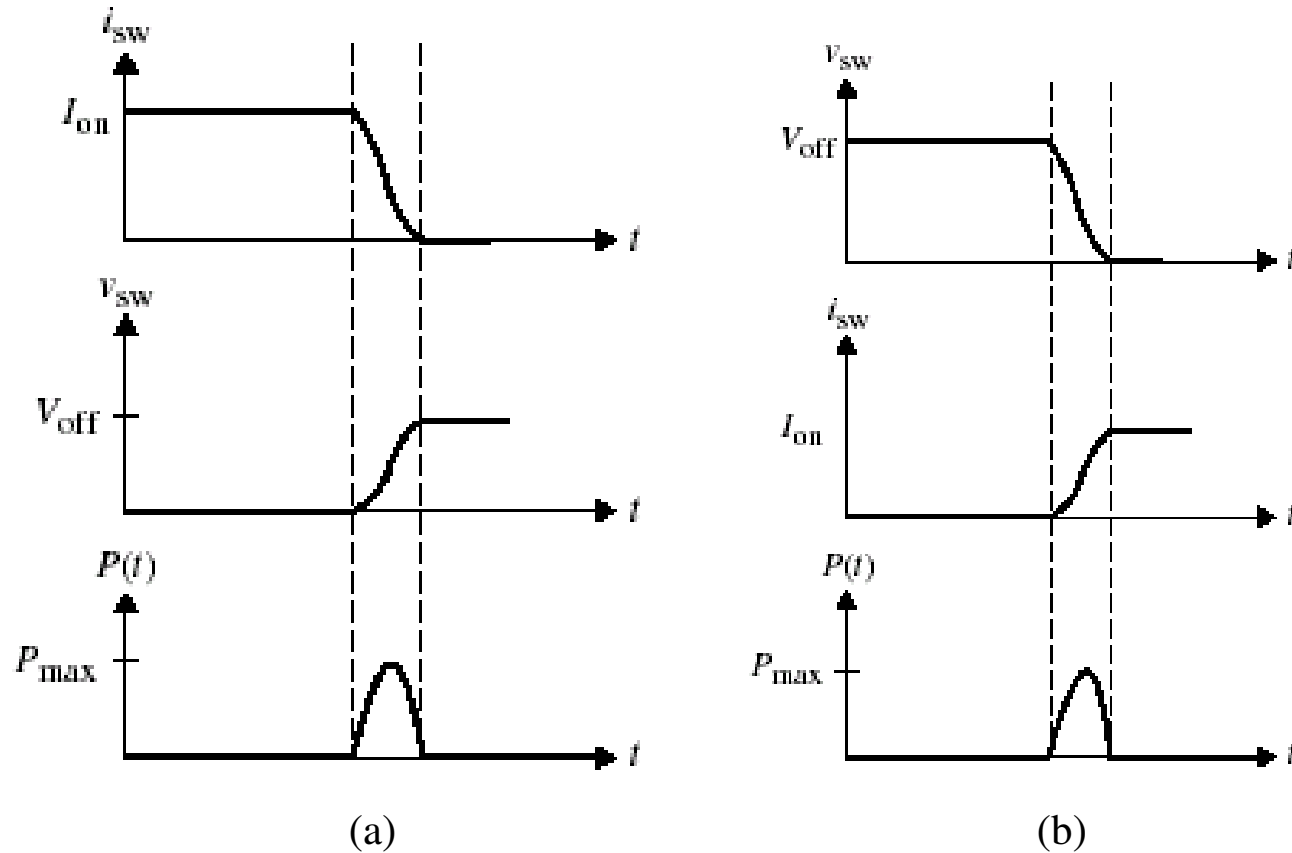

**Fig 6.4** Typical switching current, voltage, and power loss waveforms at (a) turn-off and (b) turn-on.



# Soft Switching Locus

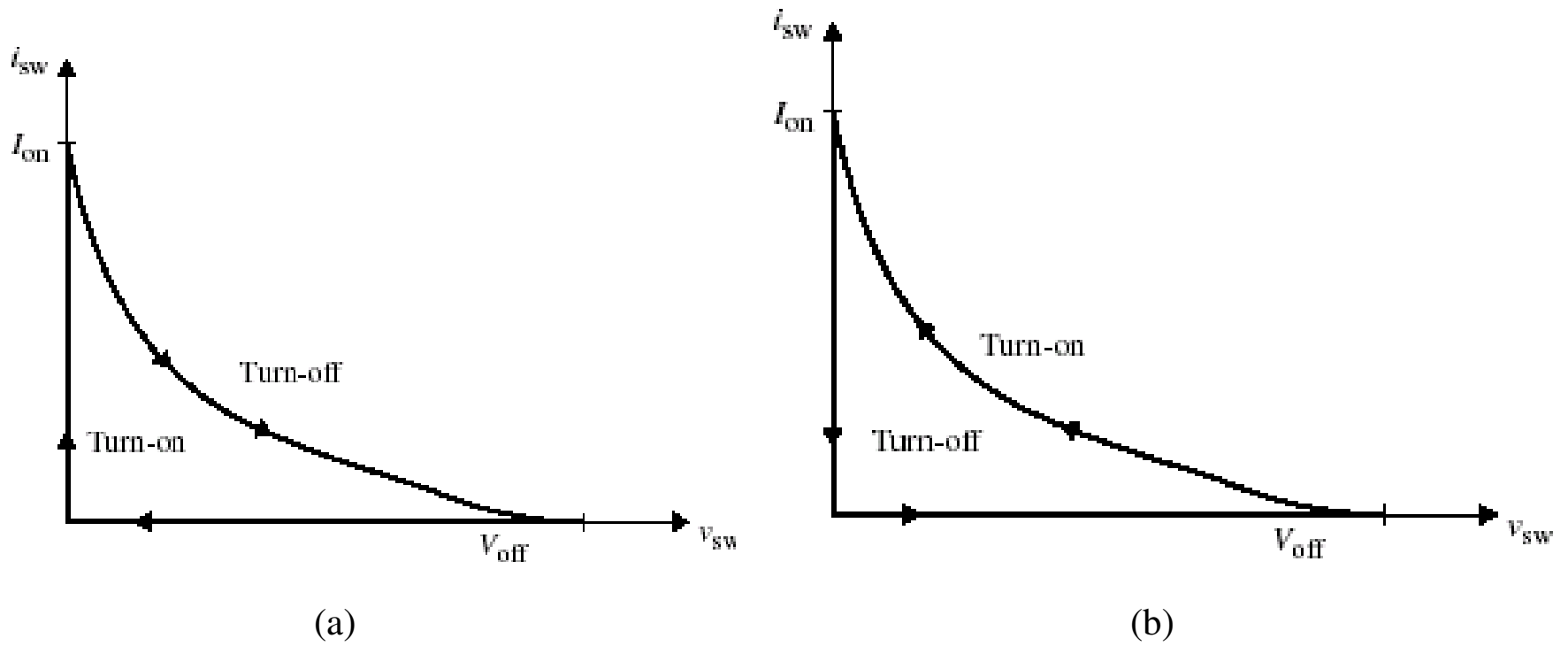
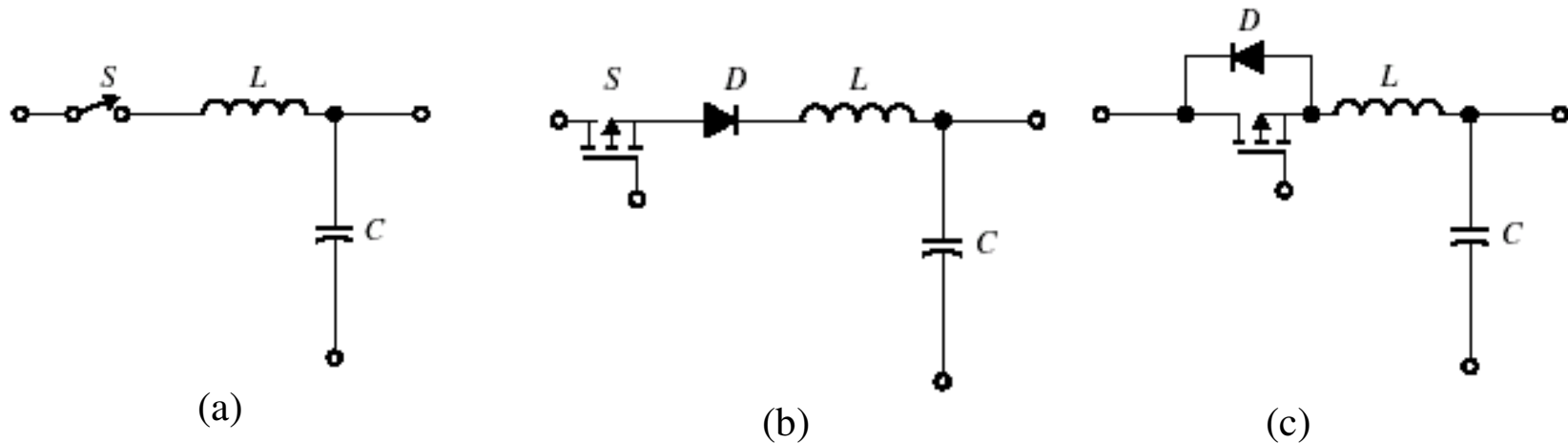

**Fig 6.3** (a) ZVS at turn-on. (b) ZCS at turn-off.

# Zero-Current Switching Topologies

## The Resonant Switch

- Depending on the inductor-capacitor arrangements, there are two possible types of resonant switch arrangements
- The switch is either an L-type or an M-type and can be implemented as a half-wave or a full-wave, i.e. unidirectional or bi-directional
- LC tank forms the resonant tank that causes ZCS to occur



**Fig 6.5** Resonant switch. (a) L-type switch. (b) Half-wave implementation. (c) Full-wave implementation.

# Resonant switch (cont'd)

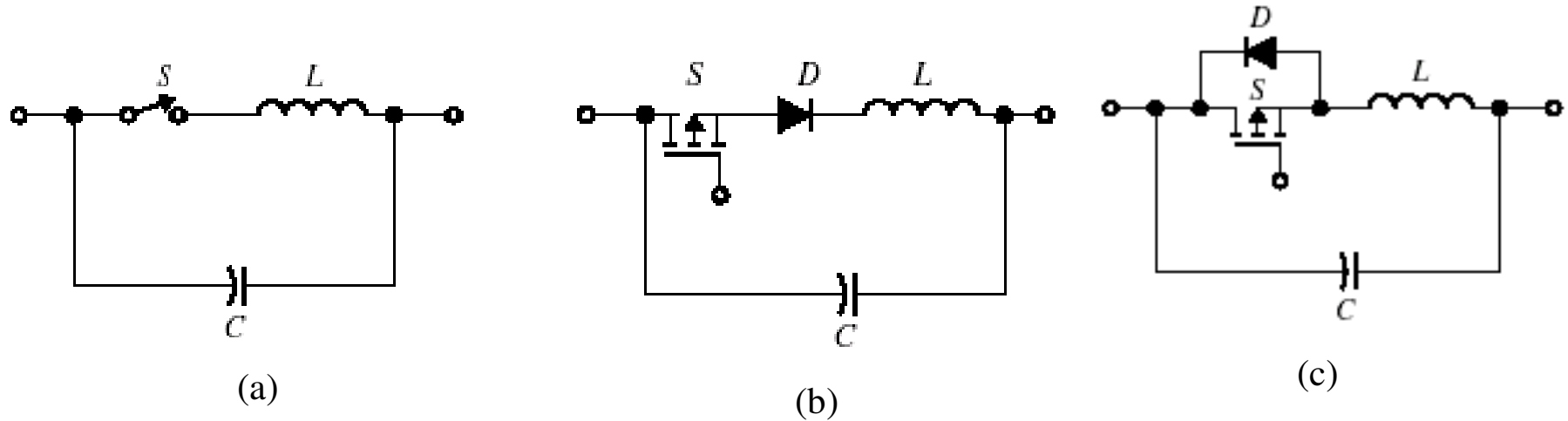

**Fig 6.6** Resonant switch. (a) M-type switch. (b) Half-wave implementation. (c) Full-wave implementation.

## Steady-State Analysis of Quasi-Resonant Converters

- To simplify the steady-state analysis
  - The filtering components  $L_o$ ,  $L_{in}$ ,  $L_F$  and  $C_o$  are large when compared to the resonant components  $L$  and  $C$
  - The output filter  $L_o$  -  $C_o$  - R is treated as a constant current source  $I_o$
  - The output filter  $C_o$  - R is treated as a constant voltage source  $V_o$
  - Switching devices and diodes are ideal

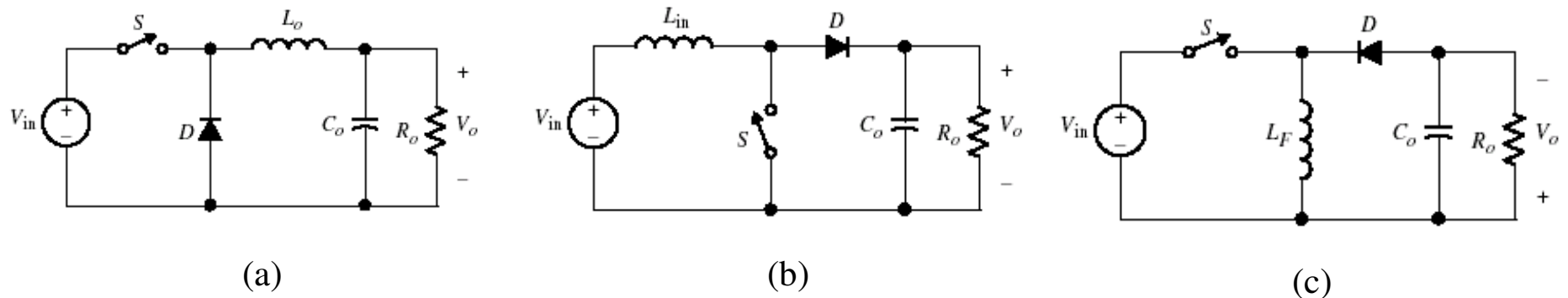

**Fig 6.7** Conventional converters: (a) buck, (b) boost, and (c) buck-boost

# The Buck Resonant Converter

- Replacing the switch by the resonant-type switch, to obtain a quasi-resonant PWM buck converter
- It can be shown that there are four modes of operation under the steady-state condition

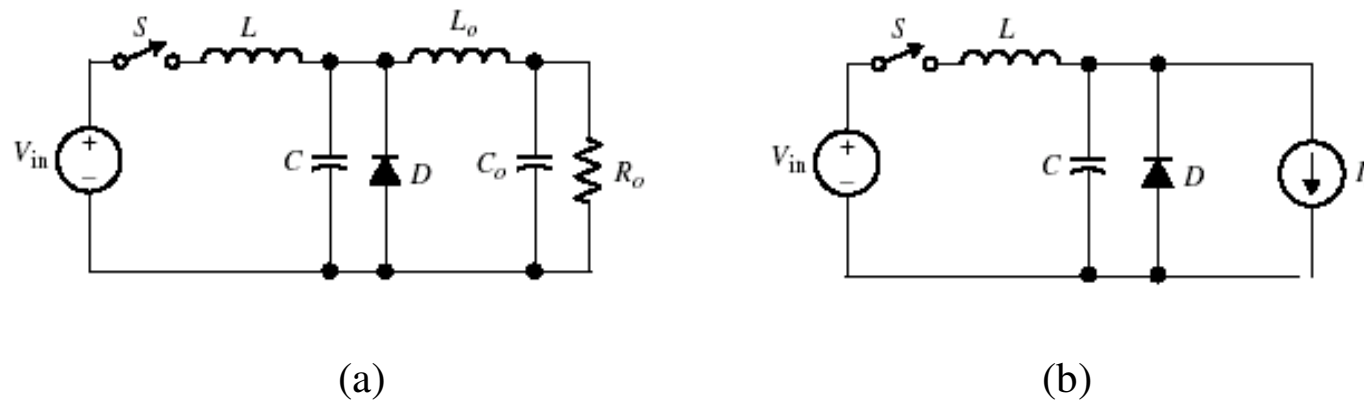

**Fig 6.8** (a) Conventional buck converter with L-type resonant switch. (b) Simplified equivalent circuit.